



Sight Glass

Sight glasses are installed after the filter drier in liquid line of refrigerating systems, in order to observe property changes of the refrigerant (liquid/vapor) and to indicate the moisture level by colors.



FEATURES

- HIGH PRECISION COLOR INDICATOR
- INDICATOR PASTED CLOSELY TO THE GLASS TO PREVENT SURFACE CONTAMINATION
- SOLID AND CORROSION RESISTANT BRASS MATERIAL
- GOOD READABILITY DUE TO HIGH CLEAR SIGHT GLASS OF WIDE ANGLE
- SEALING OF LOW CREEP PTFE TO ENSURE LEAKAGE FREE PERFORMANCE

GENERAL SPECIFICATIONS

- Applicable for all common HCFC and HFC refrigerants such as: R22, R134a, R404A, R407C, R410A, R507A...
- Ambient temperature min./max.: -50°C / +80°C
- Medium temperature TS min./max.: -50°C / +80°C
- Max. operating pressure PS: 4,6 MPa (46 bar)
- Installation position:
 - Liquid and suction line
 - Preferably in vertical lines, recommended position for horizontal lines is upwards without inclination in any direction
- Declaration according to PED

CHARACTERISTICS

Version with solder connections

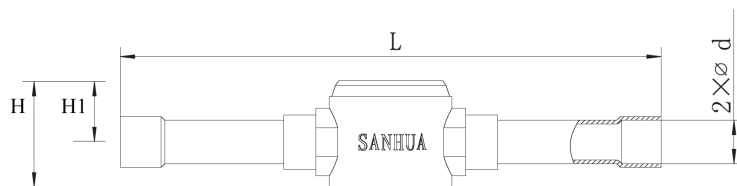

Solder Connection





SANHUA SYJ SERIES Sight Glass

Model Solder	Connection Type	Connections ODF		Dimensions & Weight				PED category	Part Number
		Ød		L	H	H1	Weight		
		[inch]	[mm]	[mm]	[mm]	[mm]	[g]		
SYJ-A00061-000	solder	-	6	101	24	14	100	3.3	SYJ-42001
SYJ-A00040-000	solder	1/4	-	101	24	14	100	3.3	SYJ-42002
SYJ-A00060-000	solder	3/8	-	119	24	14	100	3.3	SYJ-42003
SYJ-A00101-000	solder	-	10	119	24	14	100	3.3	SYJ-42004
SYJ-A00080-000	solder	1/2	-	146	30	17	200	3.3	SYJ-42005
SYJ-A00121-000	solder	-	12	146	30	17	200	3.3	SYJ-42006
SYJ-A00100-000	solder	5/8	16	146	30	17	200	3.3	SYJ-42007
SYJ-A00120-000	solder	3/4	-	173	37	21	300	3.3	SYJ-42008
SYJ-A00140-000	solder	7/8	22	173	37	21	300	3.3	SYJ-42009

Version with thread connections

Model Flare	Connection Type	SAE Flare	Dimensions & Weight				PED category	Drawing	Part Number
		Ød	L	H	ØD	Weight			
		[inch]	[mm]	[mm]	[mm]	[g]			
SYJ-A02040-000	flare	1/4	67	24	14	110	3.3	A	SYJ-42010
SYJ-A02060-000	flare	3/8	82	24	14	240	3.3	A	SYJ-42011
SYJ-A02080-000	flare	1/2	88	30	17	240	3.3	A	SYJ-42012
SYJ-A02100-000	flare	5/8	104	30	17	320	3.3	A	SYJ-42013
SYJ-A02120-000	flare	3/4	110	32	15	340	3.3	B	SYJ-42014

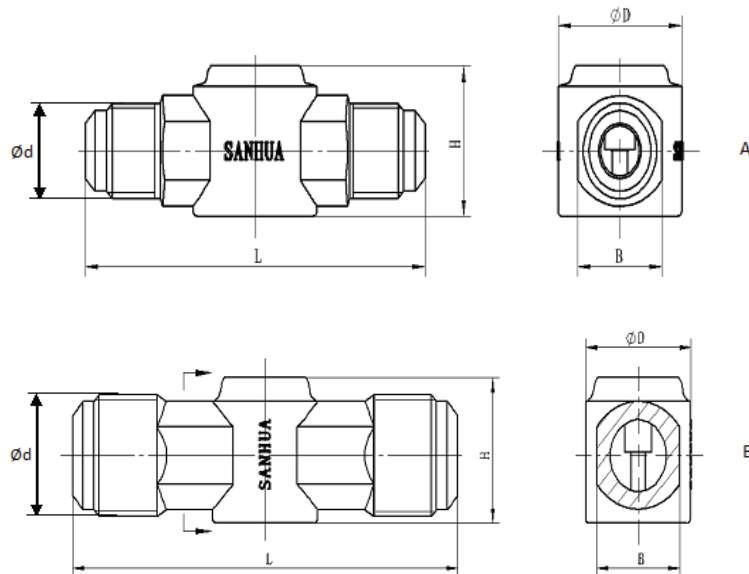



SANHUA SYJ SERIES Sight Glass

Moisture Indication Limits

Refrigerant	Moisture Content 25°C: PMM		
	Green/Dry	Middle Color	Yellow/Wet
R22	<30	30~90	>90
R134a	<50	50~200	>200
R404A	<15	15~90	>90
R507	<15	15~90	>90
R407C	<120	120~280	>280
R410A	<75	75~150	>150

Refrigerant	Moisture Content 40°C: PMM		
	Green/Dry	Middle Color	Yellow/Wet
R22	<45	45~130	>130
R134a	<80	80~225	>225
R404A	<30	30~140	>140
R507	<30	30~140	>140

